



intercontinental



MOBILIER & AGENCEMENT
POUR CABINET DENTAIRE

DES SOLUTIONS D'AGENCEMENT GLOBAL

Les solutions d'agencement global d'Intercontinental permettent d'agencer à la fois la salle de soins et la stérilisation mais également toutes les autres pièces du cabinet, actives, semi-actives ou passives :

- MEUBLE DE CABINET
- MEUBLE DE STÉRILISATION
- BANQUE D'ACCUEIL ET BUREAU
- CABINET DE TOILETTE ET POINT D'EAU
- SALLE DE REPOS ET KITCHENETTE...

DU MOBILIER DE QUALITE

Tous les meubles fabriqués par Intercontinental sont livrés montés. Une qualité d'assemblage qui garantit une robustesse dans le temps sans équivalent. Les charnières et systèmes de fermeture avec amortisseurs de fin de course intégrés, supportent des charges et un nombre d'ouvertures/fermetures bien au delà des standards du marché du mobilier livré à plat.

- MEUBLES LIVRÉS ASSEMBLÉS ET MONTÉS
- CAPACITÉ D'ÉVOLUTION DU MATÉRIEL
- MOBILIER CONTRÔLÉ ET GARANTI 5 ANS

DU MOBILIER TECHNIQUE POUR UN USAGE PROFESSIONNEL

Intercontinental met ses 40 ans d'expertise, acquise aux côtés de nombreux dentistes et professionnels, au service de l'art dentaire. La prise en compte des gestes et de la pratique est l'élément central qui motive la conception et la fabrication de notre mobilier :

- ERGONOMIE : ANALYSE DES POSITIONS ET DES SÉQUENCES DE TRAVAIL
- RATIONALISATION DE LA COMMUNICATION
- RESPECT TOTAL DES CONTRAINTES D'HYGIÈNE
- ANALYSE DES IMPÉRATIFS LIÉS AU PATIENT
- INTÉGRATION TOTALE DES PÉRIPHÉRIQUES
- SUR-MESURE : ADAPTATION À L'ENVIRONNEMENT



intercontinental

40 ANS D'ENGAGEMENT FAMILIAL

Aujourd'hui dirigée par Stefan et Manuel Ghirardello, la marque Interconfidential s'appuie sur 3 générations de fabricants de mobilier pour produire des meubles de qualité, spécialement conçus à l'usage des cabinets dentaires.

Une collaboration née de la rencontre entre le fondateur, ébéniste de formation et un dentiste de la région désireux d'un agencement ultra ergonomique pour son cabinet.

Toujours fabriqués à Guilherand-Granges en Ardèche, berceau de l'entreprise, le mobilier Interconfidential peut être réalisé entièrement sur-mesure, nos conseillers techniques sont à votre disposition au :

04 75 44 94 07

SPÉCIALISTE FRANÇAIS DU MOBILIER POUR CABINET DENTAIRE DEPUIS 1976

FABRIQUÉ
EN FRANCE

MADE IN
FRANCE



ERMÈS

meuble de cabinet sur-mesure



Intercontidental propose également la création d'espaces bureau intégralement sur-mesure (bureaux, meubles de rangements...). Renseignez-vous.

Intercontidental also offer tailor made office space solutions (desks, filing, storage units...). Ask for more details.



Plan de travail en résine Solid Surface
Solid Surface worktop



- ✧ Mobilier adaptable sur-mesure
- ✧ Plan de travail en béton de synthèse SMO™ moulé d'une seule pièce ou en Solid Surface pour des implantations sur-mesure en angle
- ✧ Grand choix d'associations de coloris
- ✧ Ouverture des tiroirs au choix :
 - Sans poignée avec Push-Latch manuel
 - Poignées
- ✧ Ouverture totale des tiroirs avec amortisseurs intégrés
- ✧ Casiers amovibles de rangements en option
- ✧ Modules techniques pour l'intégration des périphériques













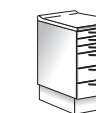
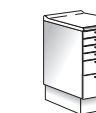
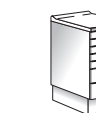
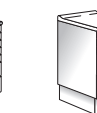

- ✧ Adaptable made-to-measure furniture
- ✧ One piece moulded SMO worktop or solid surface for made-to-measure angle set-ups
- ✧ Multiple colour choice options
- ✧ Drawer opening solutions :
 - Handleless Push-Latch
 - Handles
- ✧ Fully opening drawers with integrated soft close mechanism
- ✧ Optional removable drawer inserts
- ✧ Technical modules for total integration of peripheral devices

ERMES

meuble de cabinet sur-mesure

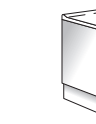
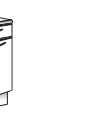

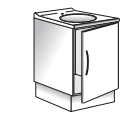
Plan de travail en résine Solid Surface
Solid Surface worktop

 <p>01 (L 50) 3T2, 1T3</p>	 <p>08 (L 50) 2T1, 2T2, 1T3</p>	 <p>02 (L 50) 3T3</p>	 <p>03 (L 50) 1T1, 1T2, 2T3</p>	 <p>04 (L 50) 1T1, 1T3, 1T2, 1T3</p>	 <p>11 (L 50) 1T1, 1T2, 1T1, 1T2, 1T3</p>	 <p>20 (L 50) 3T1, 3T2</p>	 <p>22 (L 50) 4T1, 1T2, 1T3</p>	 <p>26 (L 50) 5T1, 2T2</p>	 <p>25 (L 50) 3T1, 2T3</p>
 <p>50 (L 50) 1T1, 1T3 + 1 tiroir pour dossiers suspendus 1T1, 1T3 + 1 drawer for suspension files</p>	 <p>21 (L 40) 4T1, 1T2, 1T3</p>	 <p>23 (L 80) 4T1, 1T2, 1T3</p>	 <p>53 (L 80) 5T2, aménagement intérieur TUB* possible 5T2 option for fitting interior TUB*</p>	 <p>112 (L 50) 1T2, 1 porte, 1 étagère verre réglable 1T2, 1 door, 1 adjus- table glass shelf</p>	 <p>102 (L 30, 40, 50 ou 60) 1 porte**, 2 étagères verres réglables 1 door**, 2 adjustable glass shelves</p>	 <p>106 (L 70, 80, 90 ou 100) 2 portes, 2 étagères mélaminé 2 doors, 2 melamine shelves</p>	 <p>160 (L Sur-mesure) Garage sur-mesure avec panneau arrière renforcée Made-to-measure space between 2 units with reinforced back</p>		
 <p>202 (L 50) 1 porte ouvrante droite ou gauche** 1 door opening left or right**</p>	 <p>206 (L 50) 1 porte coulissante 1 sliding door</p>	<p>*TUB : Préciser la référence du fabricant à la commande TUB : Specify code when ordering</p> <p>** Droite ou Gauche Right or Left hand hinged</p> <p>Possibilité de composition sur-mesure Made-to-measure options available</p>							



En version Push-Latch, la composition et le nombre de tiroirs sont modifiés, renseignez-vous. In Push-Latch version, the composition and the number of drawers is modified. Ask for more information.

Ceci est un échantillon des possibilités offertes par ERMES, pour connaître tous les modules disponibles ou pour une configuration entièrement sur-mesure, contactez un conseiller Intercontinental. This is a sample of the possibilities offered by ERMES, to discover all possible modules or configurations contact your Intercontinental dealer.



Plan de travail en SMO™
SMO™ worktop



Plan de travail en résine Solid Surface
Solid Surface worktop



Plan de travail stratifié
Laminate worktop



Plan de travail en SMO™
SMO™ worktop

- ✧ Mobilier suspendu, sur banc ou socle
 - ✧ Plan de travail en béton de synthèse SMO™ moulé d'une seule pièce ou Solid Surface (modèle identique à EKITO)
 - ✧ Grand choix d'association de coloris
 - ✧ Ouverture des tiroirs au choix :
 - Touch-Latch avec assistance électrique
 - Push-Latch manuel
 - Poignées
 - ✧ Ouverture totale des tiroirs avec amortisseurs intégrés
 - ✧ Casiers amovibles de rangements en option
 - ✧ Modules techniques pour l'intégration des périphériques
 - ✧ Pour fixation murale sans socle ni banc, attention à la qualité du mur de soutien
- ✧ Wall hung cabinetry on bench or pedestal
 - ✧ Worktop moulded from a single piece of SMO™ Synthetic Resin or Solid Surface (similar example to EKITO)
 - ✧ Large choice of colour options
 - ✧ Choice of drawer opening :
 - Touch-Latch with electric opening
 - Manual Push-Latch
 - Handles
 - ✧ Fully opening drawers with integrated soft close mechanism
 - ✧ Optional removable drawer inserts
 - ✧ Technical modules for total integration of peripheral devices
 - ✧ To fix on the wall without pedestal or bench, pay attention to the quality of the support wall



Plan de travail en SMO™
SMO™ worktop



Plan de travail en résine Solid Surface
Solid Surface worktop

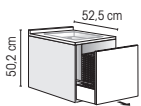

320 (L 50)
1 vasque intégrée
1 porte coulissante
1 sink, 1 sliding door



321 (L 50)
3T1, 1T2



323 (L 50)
2T1, 1T3



324 (L 50)
1T1, 2T2



325 (L 50)
1T2, 1T1, 1T2,
intérieur pour TUB*
en option
1T2, 1T1, 1T2, inside
for TUB* optional



327 (L 50)
1T2, 1T3, intérieur
pour TUB* en option
1T2, 1T3, inside for
TUB* optional



330 (L 50)
1T3, 1T2

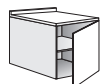

335 (L 50) D/G
1 porte**, 1 étagère
verre réglable
1 door, 1 adjustable
glass shelf



331 (L 50)
1 tirette pour TUB* Alu
Line F34, 1T1, 1T2
1 tray for TUB* in Alu
F34, 1T1, 1T2



332 (L 50)
1 tirette clavier
amovible Alu Line F34,
1T1, 1T3
1 removable keyboard
tray, Alu F34, 1T1, 1T3



333 (L 50)
1 niche, 2 tirettes Alu
Line F34, 2 PC à la
norme NF C15-100
1 open shelf, 2 trays
in Alu F34, 2 switches
to the NF C15-100
standard

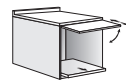

336 (L 50)
1 porte escamotable,
1 tirette en Alu Line
F34, 1 PC
1 retractable door,
1 Alu F34 tray,
1 switch



337 (L 50)
1 niche, 1 tirette en
Alu Line F34
1 open shelf,
1 Alu F34 tray

Compositions possibles :
de 1 à 5 caissons
Possible layouts :
from 1 to 5 units

Fixation murale impérative
Compulsory wall fixing

* TUB : Préciser la référence
du fabricant
à la commande

TUB : Specify code
when ordering

** Droite ou Gauche
Right or Left hand hinged



Plan de travail en SMO™
SMO™ worktop



338 (L 60 ou 80)
Socle de maintien
Load bearing
pedestal

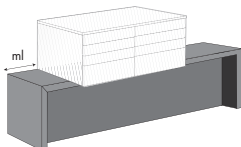

340 (sur-mesure)
Banc support avec face amovible
Support bench



EKITO

meuble de cabinet

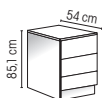

1300 (L 50)
2T3, 1T2



1400 (L 50)
4T2



1410 (L 50)
1T1, 1T2, 1T3, 1T2



1050 (L 50)
1T1, 3T2, 1T1



1055 (L 50)
1058 (L 80)
2T1, 3T2



1066 (L 50)
1080 (L 80)
4T1, 2T2



1070 (L 50)
5T1, 1T2, 1T1



1072 (L 50)
6T1, 1T2



1088 (L 50)
8T1



1108 (L 50)
1 porte escamotable
1 tirette, 2 PC, 2T2
1 retractable door
1 tray, 2 switches, 2T2



1120 (L 50)
1 niche, 1 tirette +
2 PC, 1T2, 1T1
1 open shelf, 1 tray
+ 2 switches, 1T2, 1T1



1154 (L 50)
1 niche,
2 tirettes, 2 PC, 1T1
1 open shelf,
2 adjustable trays,
2 switches, 1T1



1190 (L 35)
1 niche,
3 tirettes, 3 PC
1 open shelf,
3 trays, 3 switches



1302 (L 50)
1 vasque intégrée,
1 porte*, 1 panier fil
1 integrated sink,
1 door*, 1 basket



1306 (L 50)
1 vasque intégrée,
1 porte coulissante,
1 panier fil
1 integrated sink,
1 sliding door, 1 bin



1013 (L 30)
1015 (L 50)
1 porte*, 2 étagères
réglables
1 door*, 2 adjustable
shelves



1272 (L 30)
1 porte*, 1 étagère,
1 PC
1 door*, 1 shelf,
1 switch Internal



1200
Garage sur-mesure entre
2 éléments avec fond renforcé
Made to measure
space between 2 units
with reinforced back



- ✧ Mobilier au sol pour une installation libre sans contrainte de mur
- ✧ Plan de travail et cadre en résine Solid Surface
- ✧ Large éventail de coloris de façades
- ✧ Ouverture des tiroirs au choix :
 - Touch-Latch avec assistance électrique
 - Push-Latch manuel
 - Poignées
- ✧ Ouverture totale des tiroirs avec amortisseurs intégrés
- ✧ Casiers amovibles de rangements en option
- ✧ Modules techniques pour l'intégration des périphériques

- ✧ Floor standing cabinetry for easier installation, without wall constraints
- ✧ Solid Surface frame and worktop
- ✧ Large choice of front colour options
- ✧ Choice of drawer opening :
 - Touch Latch with electric opening
 - Manual Push Latch
 - Handles
- ✧ Fully opening drawers with integrated soft close mechanism
- ✧ Optional removable drawer inserts
- ✧ Technical modules for total integration of peripheral devices



EXCEL

meuble de cabinet



400 (L 50)
4T1, 1T2



402 (L 50)
3T1, 1T3



404 (L 50)
2T1, 2T3



406 (L 50)
1T3, 1T1, 1T2



438 (L 50)
1 porte, 1 étagère
1 door, 1 shelf



410 (L 50)
1T1, 1T2, 1T3



414 (L 50)
1T1, 1T3, 1T2



418 (L 50)
2T3



408 (L 50)
1T2, 1T1, 1T3, inférieur pour TUB en option
1T2, 1T1, 1T3, inside for TUB optional



416 (L 50)
3T2, intérieur pour TUB en option
3T2, inside for TUB optional



430 (L 50)
1 porte escamotable
1 tirette, 2 PC, 1 façade fixe
1 retractable door, 1 tray, 2 switches, 1 fixed frontage



432 (L 50)
1 porte escamotable
1 tirette, 2 PC, 1T2
1 retractable door
1 tray, 2 switches, 1T2



434 (L 50)
Niche Metal Alu 529,
2 tirettes, 4 PC
Silver 529 niche,
2 trays, 4 switches



436 (L 50)
Niche Metal Alu 529,
1 tirette, 2 PC
Silver 529 open shelf,
1 tray, 2 switches



440 (L 50)
1 tirette pour clavier
1T1, 1T3
1 keyboard tray
1 tray, 2 switches



442 (L 50)
1 tirette pour TUB*
2T1, 1T2
1 tray for TUB*,
2T1, 1T2



460 (L 50)
1 vasque, 1 porte,
1 poubelle
1 sink, 1 door, 1 bin



462 (L 50)
1 vasque, 1 porte basculante ouverture à pression,
1 poubelle
1 sink, 1 push opening drop-down door, 1 bin



464 (L 50)
1 vasque,
1 porte coulissante,
1 poubelle
1 sink, 1 sliding door, 1 bin



470 (L 35)
Niche Metal Alu 529,
2 tirettes, 4 PC
Silver 529 open shelf,
2 trays, 4 switches

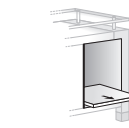

472 (L 35)
Niche Metal Alu 529,
1 tirette, 2 PC
Silver 529 open shelf,
1 tray, 2 switches

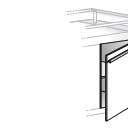

474 (L 35)
1 porte,
1 étagère verre
1 door,
1 glass shelf

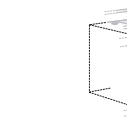

476 (L 35)
1 porte avec fond démontable, rangement mini unité centrale, 1PC
1 door with removable back, Mini central unit storage, 1 switch

*TUB : Préciser la référence du fabricant à la commande
TUB : Specify code when ordering

** Droite ou Gauche
Right or Left hand hinged

Compositions possibles : de 1 à 5 caissons
Possible layouts: from 1 to 5 units



- Mobilier adaptable de 2 à 5 modules
- Plan de travail en Solid Surface
- Façade polymère ou stratifié
- Coloris arche : pieds en MDF laque blanc brillant ou gris métallisé, sous-plateau en polymère
- Poignées City
- Portes et tiroirs avec amortisseurs intégrés
- Casiers amovibles de rangements en option
- Modules techniques pour l'intégration des périphériques

- 2 to 5 adaptable furniture
- Solid Surface worktop
- Laminate or polymer front
- Colour arch: gloss white lacquer or metallic grey MDF leg, foiled sub-plateau
- City Handles
- Fully opening drawers with integrated soft close mechanism
- Optional removable drawer inserts
- Technical modules for total integration of peripheral devices



Plan de travail en résine Solid Surface thermoformée
Thermoformed Solid Surface worktop

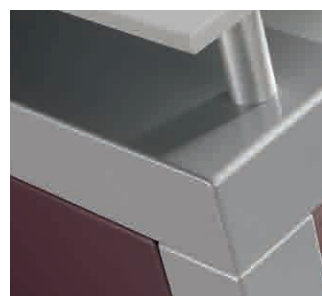

Coloris arche : pieds en MDF laque blanc brillant ou gris métallisé, sous-plateau en polymère
Colour arch: gloss lacquer white or metallic grey MDF leg

EPURE

meuble de stérilisation





Composition et agencements illimités :

Angles, découpes, contraintes techniques, composition totalement sur-mesure, renseignez-vous auprès de votre revendeur (Conseil, étude, plan 3D...)

Unlimited possible layouts :

Angle, cut out... made to measure solution. Contact your dealer.

La stérilisation est au centre de l'asepsie dentaire. A chaque étape du processus, le mobilier d'Intercontidental est conçu pour intégrer l'ensemble des équipements présents sur le marché. Robustes, ils résistent durablement aux charges lourdes et à l'usage intensif imposé par la pratique professionnelle.

Les stérilisations Epure peuvent être intégralement agencées sur-mesure et s'adapter à toutes les contraintes techniques et spatiales (gaines techniques, recoins, poteaux...). Renseignez-vous.

Sterilisation is at the centre of dental asepsis. At each stage of the process, Intercontidental cabinetry is designed to integrate all the equipment present on the market. Robust, they are resistant to heavy loads and the intensive usage imposed by professional dental practice.

Epure sterilization can be tailor made to technical and space restrictions (pipe and cable ducts, corners, pillars ...). Ask for more information.

- ⌘ Conception et fabrication de qualité
- ⌘ Conçu et adapté pour respecter le processus de stérilisation
- ⌘ Mobilier intégralement adaptable sur-mesure
- ⌘ Plan de travail en résine Solid Surface permettant l'intégration de cuves et de périphériques techniques
- ⌘ Meubles techniques et colonnes autoclaves
- ⌘ Ouverture totale des tiroirs avec amortisseurs intégrés
- ⌘ Tous les modules prévus pour intégrer des périphériques raccordés à l'eau, sont équipés, en prévention d'éventuelles fuites d'eau, d'un bac PVC de rétention

- ⌘ High quality design and manufacture
- ⌘ Designed and adapted to facilitate the sterilization process
- ⌘ Made-to-measure furniture
- ⌘ Technical and autoclave units
- ⌘ Worktop in Solid Surface Resin allows technical equipment integration
- ⌘ Fully opening drawers with integrated soft close mechanism
- ⌘ All modules designed to integrate with water connected devices are fitted with a waterproof tray preventing possible leaks

EPURE

meuble de stérilisation

le processus de stérilisation / stérilization process



Ceci est un échantillon des possibilités offertes par EPURE, pour connaître tous les modules disponibles ou pour une configuration entièrement sur-mesure, contactez un conseiller Intercontinental. This is a sample of the possibilities offered by ERMES, to discover all possible modules or configurations contact your Intercontinental dealer.

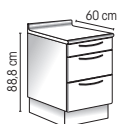

658 (L 40, 50, 60)
1T2, 2T4



657 (L 40, 50, 60)
3T2, 1T4



656 (L 40, 50, 60)
2T4



664 (L 40, 50, 60)
1 porte coulissante
1 sliding door



654 (L 40, 50, 60)
1 niche pour imprimante, 1T2, 1T4
1 open shelf for printed, 2T2, 1T4



651 (L 30, 40, 50, ou 60)
1 porte*, 2 étagères réglables
1 door*, 2 adjustable shelves



653 (L 70, 80, 90, 100)
2 portes, 2 étagères réglables
2 doors, 2 adjustable shelves

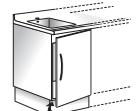

622 (L 50, 60)
Meuble sous évier, 1 porte*, 1 poubelle fil, 1 bac de rétention d'eau KM
Basin unit, 1 door*, 1 wire basket, 1 waterproof tray KM

* Droite ou Gauche
Right or Left hand hinged

Possibilité de composition sur-mesure
Made-to-measure options available



604 (L 45)
1 porte coulissante avec pédale d'ouverture, 2 bacs poubelle
1 sliding door with opening pedal, 2 bins



616 (L 50)
1 porte*, 1 bac de trempage, 1 bac de rétention d'eau KM
1 door*, 1 integrated soaking sink, 1 KM basin for holding water



614 (L 50)
1 porte*, 2 bacs de trempage intégrés, (Plan Solid Surface uniquement - bacs inox non fournis) 1 bac de rétention d'eau KM
1 door*, 2 integrated soaking sinks, 1 KM basin for holding water



607 (L 40, 50, 60)
1 porte* sans socle, 1 trappe avec couvercle sur plan de travail
1 door* without base, 1 hatch with cover on worktop

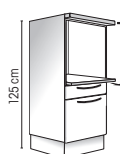

600 (60 x 60)
601 (70 x 70)
Plateau coulissant support autoclave, 1 niche, 1 tirette pour soudeuse, 1T2, 1T4
Autoclave support sliding top, 1 open shelf, 1 drawer for basing machine, 1T2, 1T4

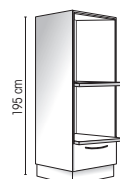

672 (60 x 70)
674 (70 x 70)
2 plateaux coulissants supports autoclaves, 1T3
2 autoclave support sliding tops, 1T3

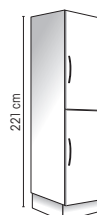

698 (L 30, 40, 50 ou 60)
Armoire de stockage
2 portes*, 8 étagères en verre
Storage cupboard
2 doors*, 8 adjustable glass shelves



ZONE HUMIDE
WET ZONE



ZONE SÈCHE
DRY ZONE

- 1 : Traitement des déchets
- 2 : Pré-desinfection
- 3 : Rinçage
- 4 : Nettoyage, désinfection & séchage
- 5 : Emballage
- 6 : Stérilisation
- 7 : Stockage

- 1 : Waste management
- 2 : Pre-disinfection
- 3 : Rinsing
- 4 : Cleaning, disinfection & drying
- 5 : Wrapping
- 6 : Sterilization
- 7 : Storage

Les meubles Intercontidental sont conçus pour intégrer la chaîne de stérilisation dans sa totalité. A chaque étape du processus correspond une série de meubles d'intégration.

Intercontidental units are designed to cover the sterilization process from start to finish. Different units correspond to each stage of the process.



ELIOT

meuble de stérilisation

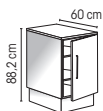

2030 (L 40)
2040 (L 50)
2050 (L 60)
1 porte*,
2 étagères réglables
1 door*,
2 adjustable shelves

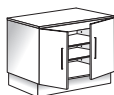

2070 (L 70)
2080 (L 80)
2100 (L 100)
2 portes, 2 étagères
réglables
2 doors, 2 adjustable
shelves



2340 (L 40)
2350 (L 50)
2360 (L 60)
1T2, 2T4



2440 (L 40)
2450 (L 50)
2460 (L 60)
3T2, 1T4

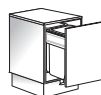

2604 (L 45)
1 porte coulissante avec
2 bacs poubelle amovibles,
pédale d'ouverture
1 sliding door with 2 removable
bins, foot operated opening

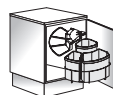

2608 (L 50)
1 porte ouvrante, 2 poubelles,
2 containers à aiguilles
1 door, 2 bins, 2 sharps
containers



2700 (L 60)
Meuble sous evier
1 porte*, 1 évier
Under-sink unit,
1 door*



2750 (L 50)
1 porte*, 2 bacs de trempage intégrés
(Plan SMO uniquement - bacs inox
non fournis)
1 door*, 2 integrated soaking
sinks (Only with SMO™ worktop)



2744 (L 40)
2745 (L 50)
1 porte*, 2 étagères réglables
1 découpe sur plan pour
encastrement appareil
1 door*, 2 adjustable shelves,
1 cut on plan for fitting device



2734 (L 60)
1 façade fixe avec grille
d'aération, 1 niche pour
appareil multifonction
1 fixed front with ventilation
grid, 1 open shelf for multi-
function equipment

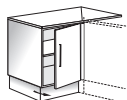

2861 D (L 90 à 100)
2863 G (L 90 à 100)
Meuble pour angle coté droit
ou gauche, 1 porte, 1 étagère
Right or left-hand corner
cupboard, 1 door, 1 shelf

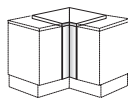

2877 (L 90)
1 plan de travail d'angle
entre 2 modules droits + 1 filler
1 corner worktop between 2
straight modules + 1 filler panel

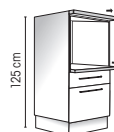

2960 (L 60)
Plateau coulissant support
autoclave, 1 niche, 1 fîrette
pour soudeuse, 1T2, 1T4
Autoclave support sliding
top, 1 open shelf, 1 drawer
for backing machine,
1T2, 1T4

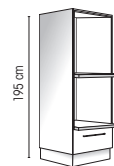

2972 (L 60)
2 plateaux
coulissants supports
autoclaves, 1T3
2 autoclave support
sliding tops, 1T3

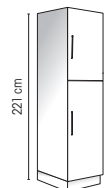

2930 (L 30)
2950 (L 50)
Armoire de stockage,
2 portes*, 1 séparation,
8 étagères verre
Tall storage unit,
2 doors*, 1 separation,
8 glass shelves

Compositions possibles : Illimitées et sur-mesure avec un plan stratifié
Possible layouts : unlimited and made-to-measure with a laminated worktop

* Droite ou Gauche
Right or Left hand hinged



- ⌘ Excellent rapport qualité/prix
- ⌘ 2 types de plan de travail disponibles : stratifié ou Solid Surface
- ⌘ Meubles techniques pour l'intégration du matériel de stérilisation
- ⌘ Evier inox fourni sur les plans stratifiés
- ⌘ Mobilier au sol pour une installation libre sans contrainte de mur
- ⌘ Ouverture totale des tiroirs pour une utilisation ergonomique
- ⌘ Colonne autoclave simple ou double
- ⌘ Poignée chromée Vita

- ⌘ Excellent value for money
- ⌘ 2 types of worktops available: laminated or Solid Surface
- ⌘ Technical furniture for integration of sterilization material
- ⌘ Stainless steel sink provided on laminated worktops
- ⌘ Floor standing cabinetry for an easier installation, without wall constraints
- ⌘ Fully opening drawers for an ergonomic use
- ⌘ Simple or double autoclave column
- ⌘ Vita chrome-plated handles



Cuve-évier et bacs de trempage en Solid Surface
Chemical dip tanks and sink in Solid Surface



MEUBLES HAUTS / WALL UNITS

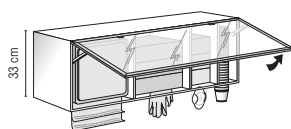

528 (P 20)
(L 100 x H 33)
Meuble hygiène porte relevable sur cadre alu, distributeurs de gobelets, masques, gants, serviettes
1 frosted glass aluminium frame lift up door, 1 cup, masks, gloves and paper dispenser

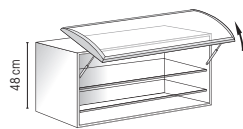

551 (P 33)
(L 70, 90 x H 48)
1 porte PMMA blanc sur cadre alu galbé relevable, 2 étagères verre, existe aussi en profondeur 35,5 cm spécial TUBS
1 white PMMA aluminium frame lift up door, 2 glass shelves, also available in depth 35.5 cm for TUBS



556 (P 20) **557** (P 33)
(L 70, 80, 90, 100 x H 48)
2 portes, 1 séparation centrale, 2 x 2 étagères verre réglables
Wall unit, 2 opening doors, 1 central separation, 2x2 adjustable glass shelves

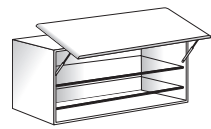

563 (P 33) **575** (P 35,5)
(L 70, 100 x H 48)
1 porte relevable, 2 étagères verre, existe aussi en profondeur 35,5 cm spécial TUBS
1 lift up door, 2 glass shelves, also available in depth 35.5 cm for TUBS



565 (P 35,5)
(L 100 x H 48)
1 porte relevable, 2 étagères verre, existe aussi en profondeur 33 cm spécial TUBS
1 lift up door, 2 glass shelves, also available in depth 33 cm for TUBS

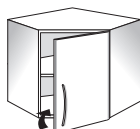

541
(L 65 x 65 x H 48)
Meuble d'angle, 1 porte, 1 étagère en mélaminé
Corner wall unit, 1 door, 1 internal shelf

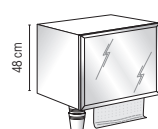

568 (P 20) **569** (P 33)
(L 50 x H 48)
1 porte miroir cadre alu, 1 étagère verre, distributeurs de serviettes en papier et gobelets
1 mirror aluminium frame door, 1 glass shelf, cups & paper dispenser

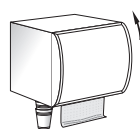

562 (P 20)
(L 50 x H 48)
1 porte PMMA blanc sur cadre alu galbé relevable, distributeurs de gobelets, serviettes
1 white PMMA aluminium frame lift up door, 1 cups & paper dispenser

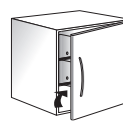

554 (P 20) **555** (P 33)
(L 30, 40, 50, 60 x H 48)
1 porte, 2 étagères verre réglables
1 door, 2 adjustable glass shelves

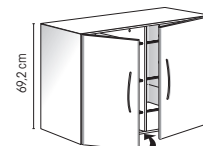

586 (P 20) **587** (P 33)
(L 70, 100 x H 69,2)
1 porte relevable, 2 étagères verre, existe aussi en profondeur 35,5 cm spécial TUBS
1 lift up door, 2 glass shelves, also available in depth 35.5 cm for TUBS



Ceci est un échantillon des meubles hauts disponibles.
Renseignez-vous auprès de votre revendeur.
This is a sample of the possibilities, to discover all possible modules or configurations contact your Intercontinental dealer.

P : Profondeur / Depth
L : Largeur / Width
H : Hauteur / Height



MEUBLES MOBILES / MOBILE UNITS



61
(L 51,5 x H 76,7 x P 46,5)
3T1, 2T2

Disponible seulement
en coloris Fxx
Only available in Fxx
colours



69
(L 50 x H 74 x P 45)
3T1



920
(L 54 x H maxi 105/
H mini 85,5 x P 49)
3T1, 1T2



En Solid Surface la tablette bénéficie
d'une poignée de préhension.
The Solid Surface top is fitted with a
gripping handle.



⚡ Tablette en Béton de Synthèse SMO™
ou en Solid Surface (blanc)
⚡ Coloris assortis à la gamme, renseignez-vous

⚡ SMO™ Synthetic Resin tray or in Solid Surface (white only)
⚡ Available in all colours, please ask for more information

FAÇADES / FRONT

EKITO / EOL / ERMES / EXCEL / EPURE



F01* Neige **F03*** Pergamon **F08** Polaire **F17** Clementine **F19** Indigo **F27** Kiwi **F47** Milano **F50*** Noir **F62*** Latte

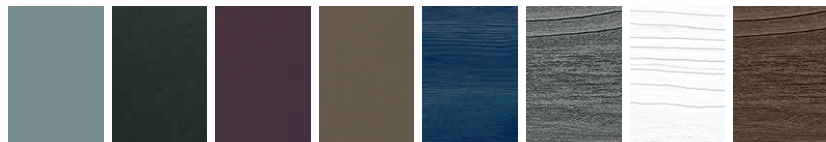

F65 Fjord **F70*** Stardust **F71** Aubergine **F73** Moka **F75** Magic Blue **F77** Magic Sylver **F81** Edelweiss **F83** Basalt

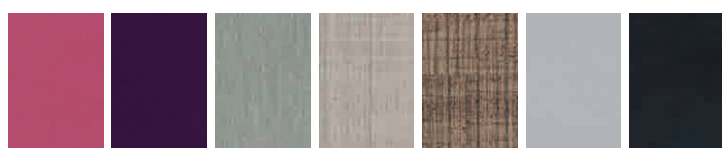

432* Fushia **434*** Prune **529** Metal Alu **713** Lin **729** Chêne Tissé **808*** Cendre **814*** Smoke

(*) COLORIS BRILLANTS

ELIOT



M410* Neige **M411** Polaire **M529** Métal Alu

(*) COLORIS BRILLANTS



COLORIS CAISSONS

EKITO / ELIOT : M411 Blanc
EOL / ERMES / EXCEL / EPURE : 529 Metal Alu

EXCEL : le plan sous-vasque n'est disponible que dans les coloris polymère (Fxx).

EOL : Les socles et bancs ne sont disponibles que dans les coloris stratifiés

POIGNÉES / HANDLES

Poignée Smart
Smart handle



EKITO / EOL / ERMÈS / EPURE

Poignée Aurore
Aurore handle



EKITO / EOL / ERMÈS / EPURE

Poignée Luna
Luna handle



EOL / ERMÈS / EPURE

Poignée City
City handle



EXCEL

Poignée Capia
Capia handle



ERMÈS

Poignée Vita
Vita handle



ELIOT

PLANS DE TRAVAIL / WORKTOP

STRATIFIÉ

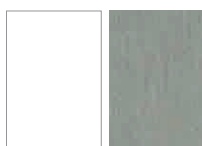

M411
Polaire

M529
Métal Alu



Vasque céramique encastrée sous plan de travail stratifié.
Integrated ceramic sink on laminate worktop.



Cuve évier inox.
Inox sink.

PLANS DE TRAVAIL / WORKTOP

SMO™

Le Béton de Synthèse SMO™ fabriqué par Intercontinental, est un matériau unique, mélange de pierres naturelles liées par une résine et recouvert d'un gelcoat de protection de 1mm d'épaisseur. Un matériau permettant de réaliser une multitude de formes, de couleurs et donc d'applications. Pas de moisissure et d'infiltration d'eau possible, le Béton de Synthèse SMO™ est plus résistant aux agressions de produits dentaires, que la plupart des résines acryliques. Il est durablement efficace et idéal pour la sécurité des cabinets dentaires.

SES PROPRIÉTÉS PRINCIPALES :

- **Imputrescible, pas de moisissure**
- **Monobloc, pas de joint**
- **Facile d'entretien**
- **plus de 200 coloris possibles**

SMO™ Synthetic Resin is made by Intercontinental and is a unique material consisting of a mixture of natural stone and resins. The material is moulded to achieve a multitude of shapes, colours and applications.

MAIN PROPERTIES:

- **Rot-proof, no mould**
- **Cast in one piece, no joints**
- **Easy to clean**
- **Available more than 200 colours**



200*
Blanc

201
Blanc Mat

213
Flanelle

214*
Stella

(*) COLORIS BRILLANTS

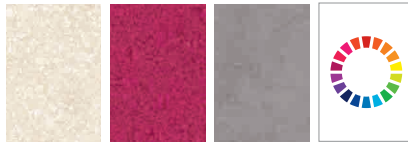

267
Nougat

274*
Amarena

379
Tadelakt

RAL*
Classic

SOLID SURFACE

La Résine Solid Surface est constituée d'un mélange de minéraux naturels et de résine acrylique. Le produit se décline suivant une gamme de couleurs variées. Esthétique et d'aspect mat, il est d'une grande résistance. Lisse et sans joint apparent, il permet de réaliser des vasques thermoformées, des angulations et des découpes sur-mesure en cabinet et stérilisation.

Solid Surface resin consists of a mixture of natural minerals with an acrylic resin. This material is always in a matt finish and available in a variety of colours. It is aesthetically pleasing and very strong and durable. Smooth and joint free, it can be manufactured with a thermoformed integrated sinks.



R010
Blanc

R418
Stratus

R645
Lily

R010
Blanc



R010
Blanc

En cas de tâche ou de marque provoquée par un produit abrasif, le ponçage et la réparation ne laissent aucune trace visible, ni faiblesse du revêtement.

To eliminate stains or marks caused by a scouring agent, sanding and repair leave no visible marks or weakness of the coating.

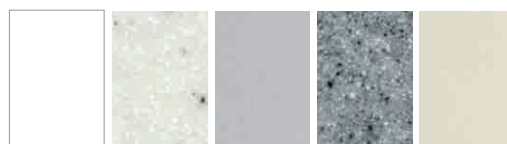
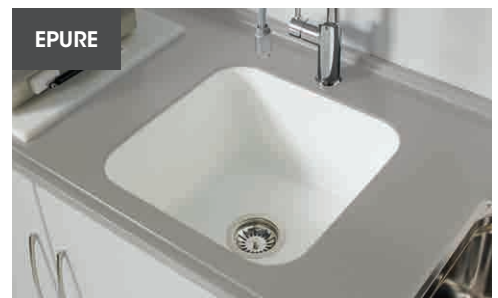

R010
Blanc

R412
Birch

R418
Stratus

R420
Grey

R645
Lily



INTÉRIEURS DE TIROIRS / DRAWER INSERTS

TIROIRS LARGEUR 50 cm - T1 / DRAWERS, WIDTH 50 cm - T1

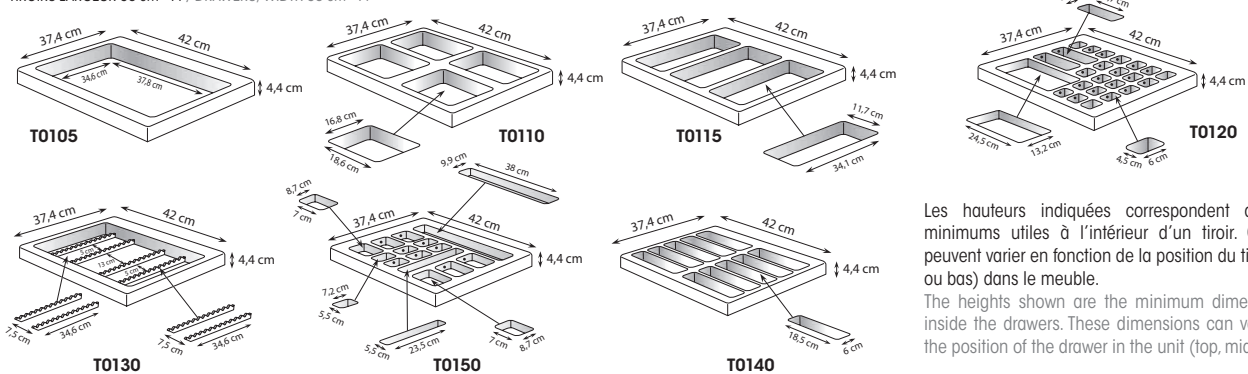

Les hauteurs indiquées correspondent aux dimensions minimums utiles à l'intérieur d'un tiroir. Ces dimensions peuvent varier en fonction de la position du tiroir (haut, milieu ou bas) dans le meuble.
The heights shown are the minimum dimensions available inside the drawers. These dimensions can vary according to the position of the drawer in the unit (top, middle or bottom).

TIROIRS LARGEUR 50 cm - T2 / DRAWERS, WIDTH 50 cm - T2

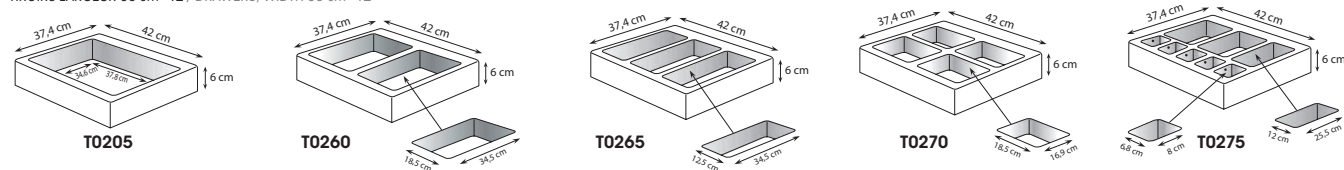

TIROIRS LARGEUR 40 cm - T1 & T2 / DRAWERS, WIDTH 40 cm - T1 & T2

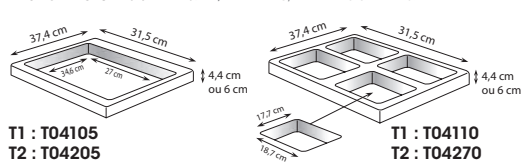

TIROIRS LARGEUR 60 cm - T1 & T2 / DRAWERS, WIDTH 60 cm - T1 & T2

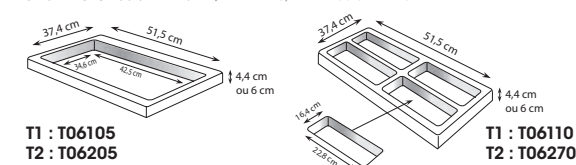

TIROIRS LARGEUR 70 cm - T1 & T2 / DRAWERS, WIDTH 70 cm - T1 & T2

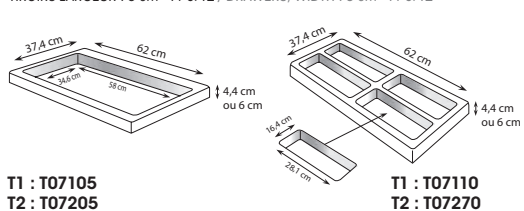

TIROIRS LARGEUR 80 cm - T1 / DRAWERS, WIDTH 80 cm - T1

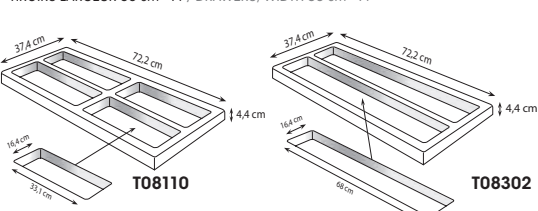

TIROIRS LARGEUR 80 cm - T2 / DRAWERS, WIDTH 80 cm - T2

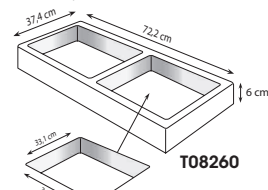

AMENAGEMENT TUB L 50 cm
TUB FITTING, W 50 cm

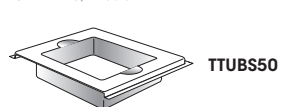

AMENAGEMENT TUB L 80 cm
TUB FITTING, W 80 cm

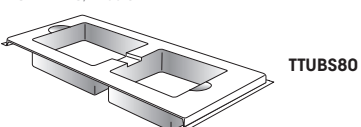

Pour tiroirs T2 uniquement. Préciser la marque du fabricant de TUBS lors de la commande. For T2 drawers only. Specify code when ordering.



Photos non contractuelles - Sous réserve d'erreurs typographiques - Tous droits réservés - Intercontidental novembre 2017

INTERCONTIDENTAL
500 rue Blaise Pascal - BP 206
07502 Guilhaud-Granges Cedex - France

France : Tél : +33 (0)4 75 44 94 07 - Fax : +33 (0)4 75 41 00 13
Email : contact@intercontidental.com
Export : Tél. : +33 (0)4 26 60 90 81 - Fax : + 33 (0)4 75 41 00 13
email : export@intercontidental.com

www.intercontidental.com



intercontidental